



Uniones
de Cobre
Copper Splices

ZCC	19
ZCC L	19
MCC	20
MTC	20



TINNED COPPER SPLICES

To indent or compress in copper conductors

SHORT

ZCC

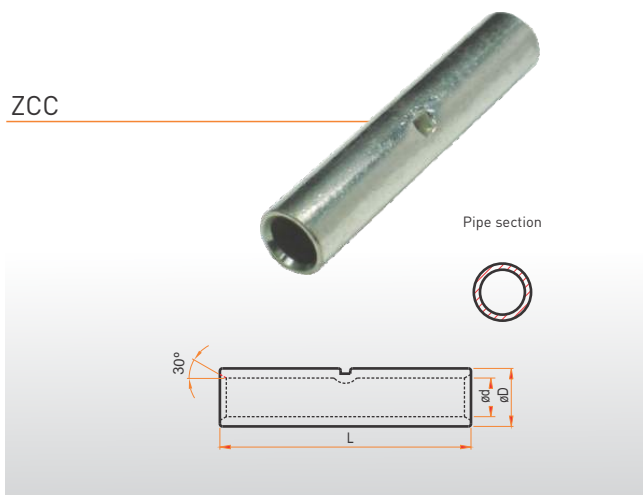

Splices to indent or compress in low voltage copper conductors that are not subjected to tensile stress. Made from electrolytic copper pipe of appropriate section and minimum conductivity of 86% IACS coated surface of tin applied by electroplating, ensuring a thick minimum of 5 microns, thereby obtaining adequate protection against corrosion and hardness suitable for making a minimal effort to correct compression. The introduction of conductors is provided with a pronounced bevel input and ensuring a central stop on both ends over the same connection.



SECTION mm ²	DIMENSIONS			PIPE SECTION	CODE
	øD	ød	L		
1,5	3,2	2,2	19,5	4,2	ZCC 1,5
2,5	4,1	2,5	19,5	8,3	ZCC 2,5
4	4,5	3,0	19,5	9,3	ZCC 4
6	5,5	3,8	19,5	12,4	ZCC 6
10	6,5	4,7	29,0	15,8	ZCC 10
16	7,5	5,5	35,0	20,4	ZCC 16
25	9,1	6,9	35,0	27,6	ZCC 25
35	11,1	8,2	35,0	43,9	ZCC 35
50	12,7	9,8	48,0	51,2	ZCC 50
70	15,0	11,5	51,0	72,8	ZCC 70
95	17,4	13,5	54,0	94,6	ZCC 95
120	19,4	15,2	57,0	114,1	ZCC 120
150	21,5	16,5	57,0	149,2	ZCC 150
185	23,8	18,6	61,0	173,1	ZCC 185
240	27,0	20,8	73,0	232,7	ZCC 240
300	30,5	23,5	73,0	296,8	ZCC 300
400	35,2	27,0	78,0	400,5	ZCC 400
500	40,0	31,0	80,0	501,8	ZCC 500
630	44,2	34,2	86,0	615,7	ZCC 630

LONG

ZCC L

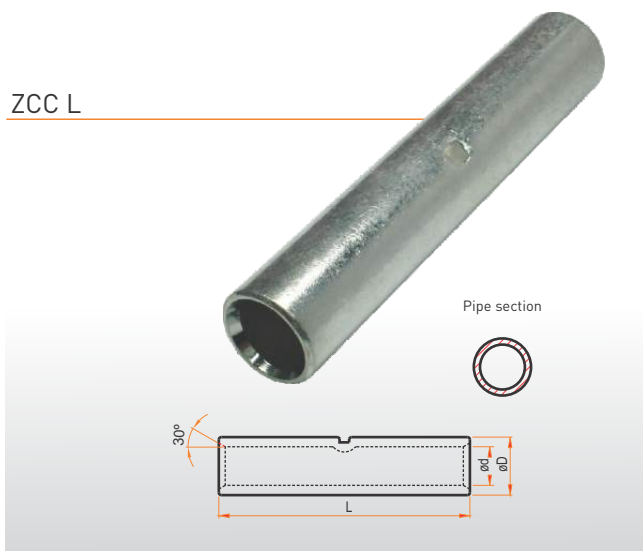

The long splices, in addition to meeting the general characteristics of the line ZCC, have a longer barrel which allows double indentation or compression that in addition to ensuring better contact surface and adhesion allows to support traction forces applied to conductor.



SECTION mm ²	DIMENSIONS			PIPE SECTION	CODE
	øD	ød	L		
10	6,5	4,7	67,0	15,8	ZCC 10 L
16	7,5	5,5	67,0	20,4	ZCC 16 L
25	9,1	6,9	67,0	27,6	ZCC 25 L
35	11,1	8,2	67,0	43,9	ZCC 35 L
50	12,7	9,8	73,0	51,2	ZCC 50 L
70	15,0	11,5	80,0	72,8	ZCC 70 L
95	17,4	13,5	80,0	94,6	ZCC 95 L
120	19,4	15,2	85,0	114,1	ZCC 120 L
150	21,5	16,5	105,0	149,2	ZCC 150 L
185	23,8	18,6	105,0	173,1	ZCC 185 L
240	27,0	20,8	118,0	232,7	ZCC 240 L
300	30,5	23,5	140,0	296,8	ZCC 300 L
400	35,2	27,0	145,0	400,5	ZCC 400 L
500	40,0	31,0	150,0	501,8	ZCC 500 L
630	44,2	34,2	156,0	615,7	ZCC 630 L

TINNED COPPER SPLICES

For compression fitting to bare copper overhead lines for BT and MT

Copper Handle

MCC

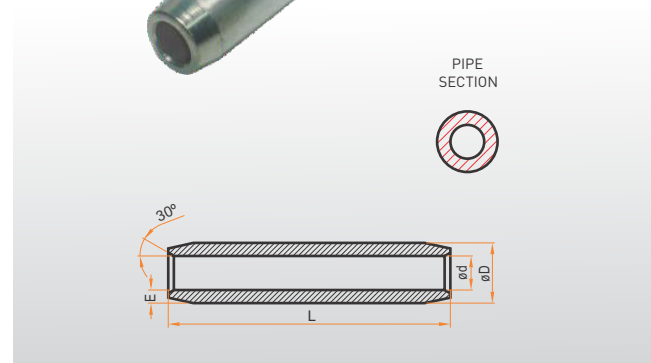

SECTION mm ²	DIMENSIONS				PIPE SECTION	CODE
	øD	ød	L	E		
10	13,0	4,7	160	4,15	115	MCC 10
16	14,0	5,5	160	4,25	130	MCC 16
25	15,0	6,9	200	4,05	139	MCC 25
35	18,0	8,2	200	4,90	201	MCC 35
50	18,0	9,8	200	4,10	179	MCC 50
70	18,0	11,5	210	3,25	150	MCC 70
95	23,0	13,5	250	4,75	272	MCC 95
120	24,0	15,2	250	4,40	234	MCC 120
150	26,0	16,5	280	4,75	317	MCC 150
185	28,0	18,6	320	4,70	344	MCC 185
240	32,0	20,8	360	5,60	464	MCC 240

Manufactured from copper pipe from appropriate section and minimum conductivity of 86% IACS. The introduction of the conductors is provided with a pronounced entry bevel that ensures that both conductors can slide correctly.

For compression fitting MT in underground lines of copper

Cloisonne Copper Handle

MTC

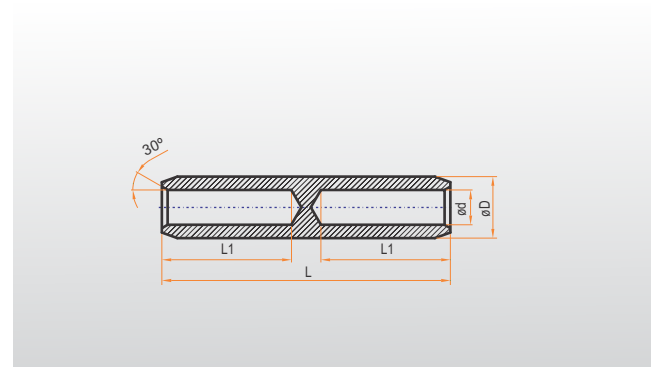

SECTION mm ²	DIMENSIONS				PIPE SECTION	CODE
	øD	ød	L	L1		
10	12,0	4,7	70,0	30,0	95	MTC 10
16	14,0	5,5	71,0	30,0	130	MTC 16
25	14,0	6,9	72,0	30,0	116	MTC 25
35	18,0	8,2	73,0	30,0	201	MTC 35
50	18,0	9,8	97,0	42,0	179	MTC 50
70	20,0	11,5	98,0	42,0	210	MTC 70
95	23,0	13,5	100,0	42,0	272	MTC 95
120	25,0	15,2	136,0	58,0	309	MTC 120
150	30,0	16,5	136,0	58,0	490	MTC 150
185	30,0	18,6	140,0	58,0	435	MTC 185
240	32,0	20,8	142,0	58,0	464	MTC 240

Manufactured from copper bar from appropriate section and minimum conductivity of 86% IACS.

The introduction of the conductors is provided with a pronounced bevel of entry that ensures that both conductors can slide properly and ensures a central partition at both ends the same length of connection and avoids the presence oil or grease with which a conductor can contaminate the other.